



U N I Q U E S Y S T E M S
F O R F I E L D I N S T R U M E N T A T I O N

INNOVATIVE PARTNER FOR COMPREHENSIVE SOLUTIONS

When it comes to creating constant, and consequently optimum, operating conditions outdoors, INTERTEC is the perfect choice for instrument protection systems.

INTERTEC is a supplier of unique systems designed to provide reliable protection of sensitive field-mounted instruments. The company was founded in 1965 by Dr.-Ing. Joachim Hess, who recognized the problem of inadequate protection of electronic instruments in the field of engineering. Neglect or failures in instrument protection, however, can seriously affect plant safety and the operation of the complete system. Even operating and maintenance costs can be reduced considerably by providing adequate instrument protection.



Today, more than half a million INTERTEC protection systems ensure safe operation of instruments, analyzers, mobile phone and radar equipment, signalling plants, transmitters and many other installations worldwide. Due to extensive expertise in engineering, constant innovation and product improvement INTERTEC has become the world's leading manufacturer in this field. Twenty patents obtained for our products and unique solutions attest to INTERTEC's know-how, and several new patents are issued every year.

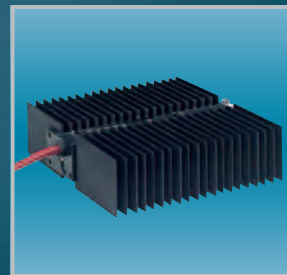

LOCATIONS

Our production sites in Belgium, Canada, Germany, Great Britain, the Netherlands and the U.S.A. have 2 300m² of office buildings, 8 000m² of production plants and 32 000 m² of open space. Marketing, sales, engineering and production are closely integrated. Our sales engineers on the road as well as our network of representatives, agents and distributors in many countries will ensure customer-oriented service worldwide.



SAFE LINK THE COMPLETE SOLUTION CONCEPT FOR FIELD INSTRUMENTATION

As practised by automotive engineers for some time, the trend in engineering and plant construction is strongly towards the supply of complete systems.

Drawing on several decades of experience, INTERTEC does not have to reinvent the wheel for every new project. Access to an intelligent modular concept allows industrial quality at competitive costs.

Benefit from our extensive experience!

The INTERTEC data base of the SAFE LINK software (ISL) helps you access optimized solutions developed by our engineers during tens of thousands of working hours and in close contact with plant operators to meet customers' specific project specifications.

SAFE LINK - A Convincing System

- Enormously reduced engineering costs
- Low material procurement costs
- Pre-installed hook-ups save time and costs at the site
- Sensible standardization reduces the variation in range of instrument installations and saves storage costs
- Field-proven and practice-proven solutions for traditional installations and innovative direct mounting
- High measuring accuracy resulting from short impulse lines

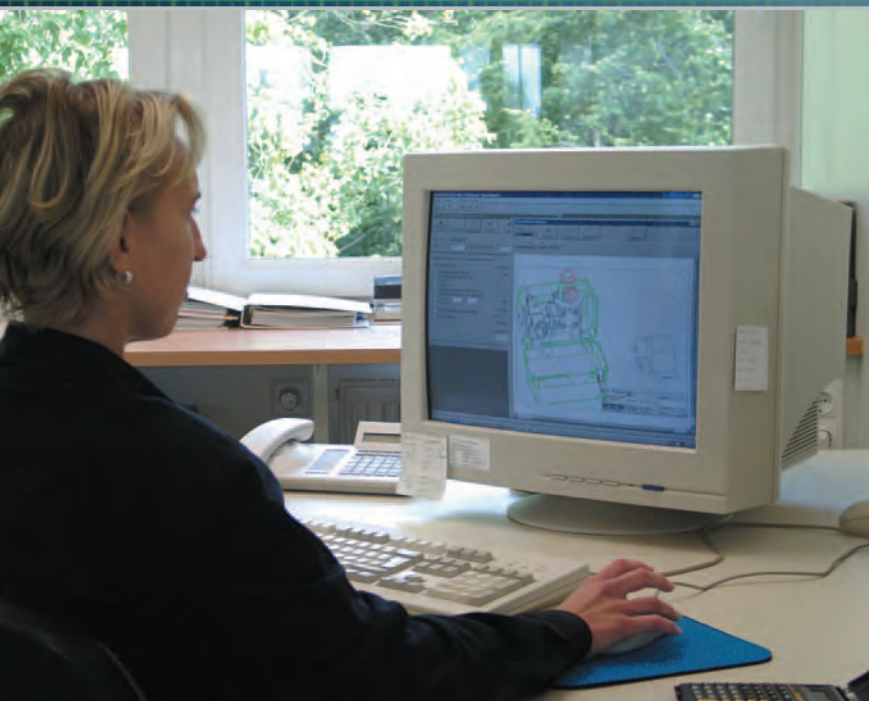
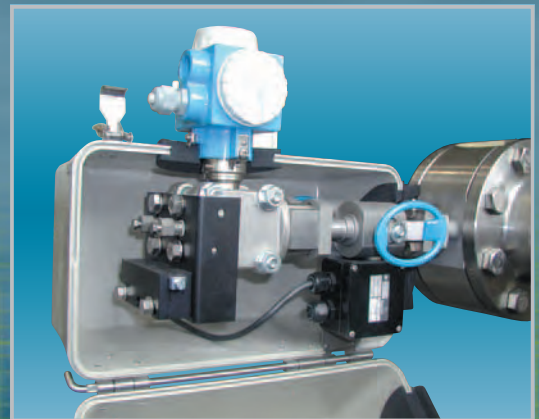

The Safe Link Package includes:

- ➔ Generation of a project standard
- ➔ Installation design
- ➔ Pre-installation of hook-ups including leak testing
- ➔ Delivery of complete units, ready to be installed in the plant
- ➔ Documentation including mounting instructions, parts lists, material certificate 3.1B to EN 10204, CAD-drawing



Cost Comparison

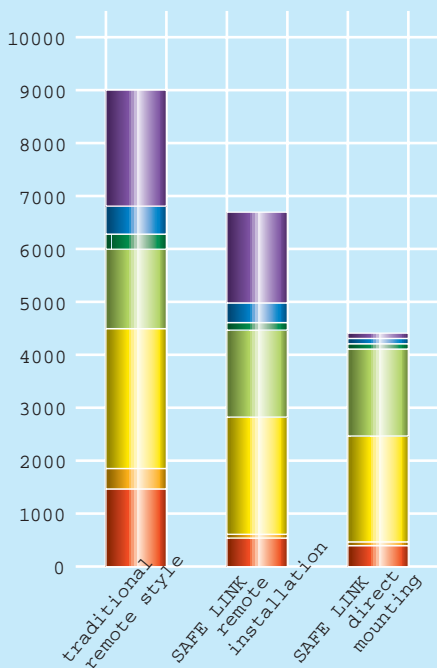

SAFE LINK for Gas Application

For pressure systems and especially for natural gas applications „double block and bleed“ configurations are required at the tapping point for reasons of safety. INTERTEC has developed a solution with only one ball valve, which fulfills the „double-block function“ and optionally the „bleed function“.



Compact Orifice

Flow measurement including sandwich orifice (with standardized dimensions), differential pressure transmitter, enclosure and heater with the advantages of an in-line meter.

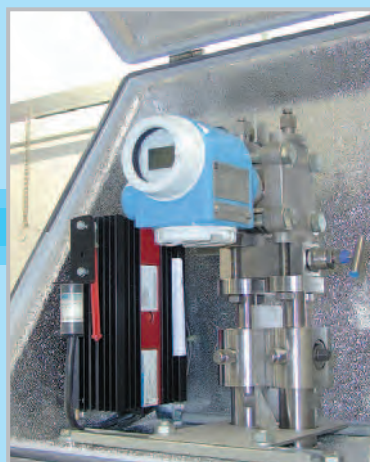
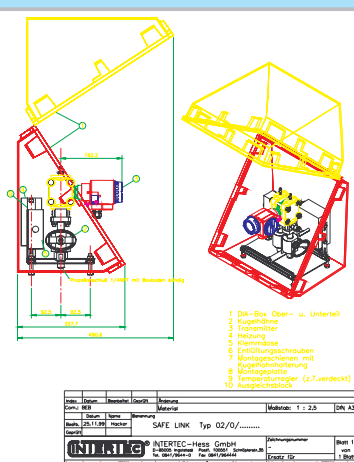
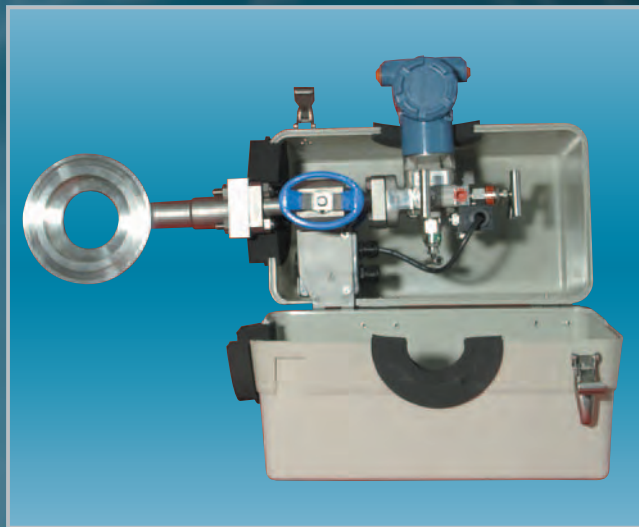

INTERTEC INSTRUMENT ENCLOSURES - RELIABLE PROTECTION FOR MEASURING INSTRUMENTS

INTERTEC instrument enclosures are made of long glass fibre reinforced polyester (GRP) in sheet moulded compound design.

This high-tech material has many advantages:

- Strength that almost matches stainless steel (non-reinforced plastic material has approx. 100 times less stability)
- The weight of stainless steel is 4 times greater
- By increasing wall thickness and optimum fibre alignment the enclosure can be made with extra reinforcing at the edges
- Corrosion-free
- Excellent chemical resistance

Electronic catalogue and design guide for easy selection and specification are available free of charge.

MULTIBOX

A versatile and proven enclosure system designed for use in a broad range of applications. MULTIBOX enclosures are available in many sizes and designs.



The Unique Concept of the Mounting Element

The mounting elements which are inserted into the reinforced recesses provided in both enclosure halves, are designed to allow for both external mounting of the enclosure and for internal installation of C-rails providing mounting for all types of heavy instrumentation. The equipment weight is transferred directly to the mounting support.

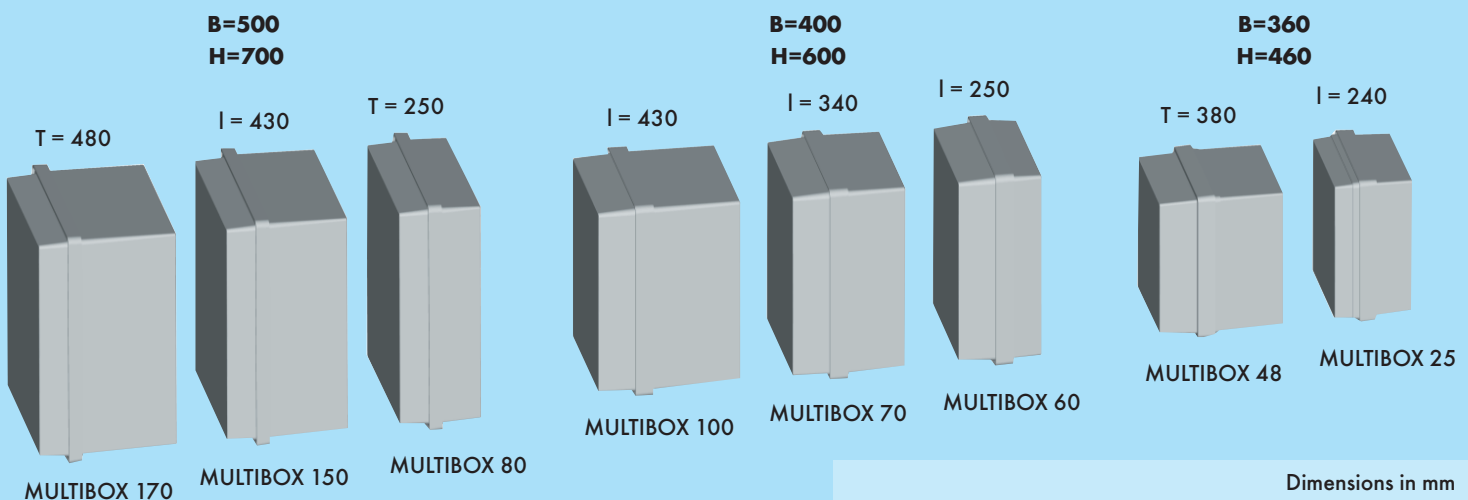
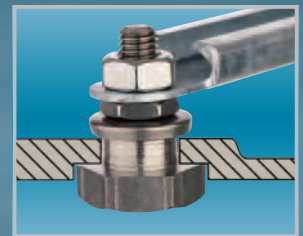

Dimensions in mm
Special sizes, forms and applications on request

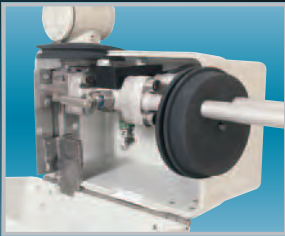

The MINIBOX is perfectly suited for direct mounting at the root valve. This partial enclosure has been designed specifically to protect the transmitter head and the electronics from overheating from the process medium.

MINIBOX



Impulse lines can penetrate the flat bottom part of the horizontally split UNIBOX from all directions. Perfect access to the instrument when the cover is open.

UNIBOX

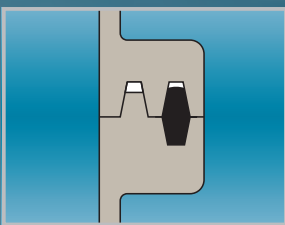

The „Sealing“ Principle

The combination of a tapered tongue and groove seal and gasket ensures optimum tightness to IP 68.

DIABOX
The diagonally split enclosure



Simple Installation

INTERTEC has developed a versatile mounting plate with pre-punched holes to mount manifolds and transmitters.



H=500
B=1000
T=500

H=490
B=700
T=390

H=490
B=575
T=390

H=490
B=450
T=390

H=380
B=380
T=310



DIABINET

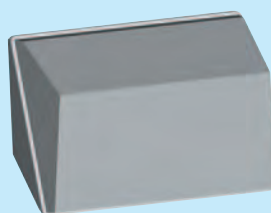

DIABOX 137

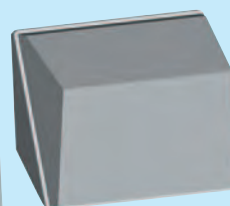

DIABOX 107

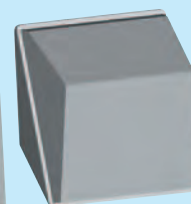

DIABOX 87

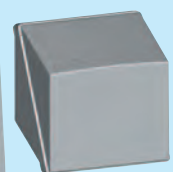

DIABOX 47

OPTIONS AND FEATURES

OPTIONS

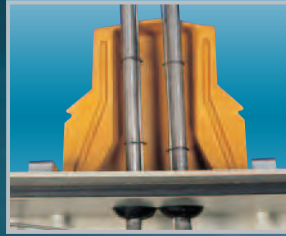

ISOPASS



Flange Plate



Vent

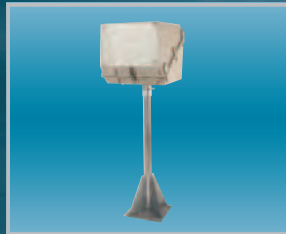

Pipe Stand



Pipe Adapter



19" frame



Lid Prop Stay



Window



Opening Window



Gas Struts

Electronic catalogue and design guide are available free of charge.

FEATURES



Clasps



Hinges



Stackable



SD 25



SD 100

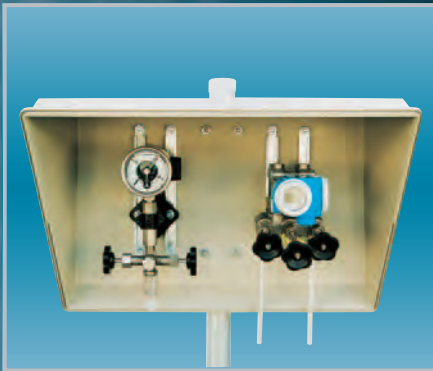

DIASHADE 137



SD 100



DIASHADE 427

SUN SHADES

INTERTEC shades made of GRP have been designed to provide protection from environmental conditions such as UV-radiation, rainfall and dust accumulation.

Heat Transfer Coefficient 'K'

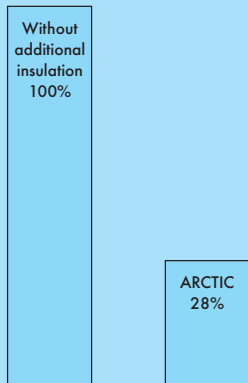

'ARCTIC' INSULATION

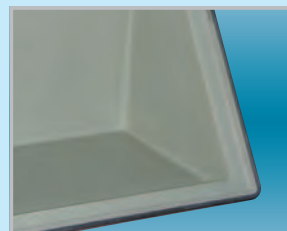

ARCTIC PP



ARCTIC Alu

PROTECTIVE CABINETS AND SHELTERS



for challenging specifications

INTERTEC cabinets and shelters are made in sandwich design with inner and outer layers of very strong GRP (or other material) and an insulating soft core of closed-cell PU-foam. This construction ensures high static strength.



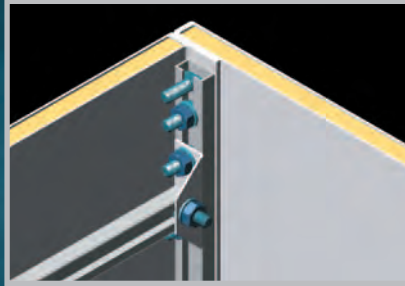

BASIC

A range of small high-quality cabinets

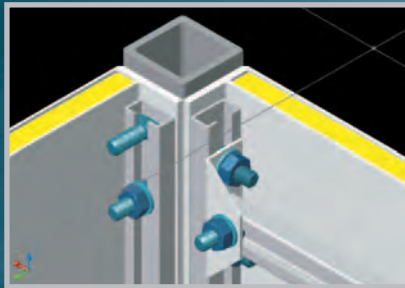
CLASSIC

The integrally mounted, infinitely adjustable C-rail mounting system or the UNISTRUT allow for installation of customer equipment. The weight of the equipment is transferred directly to support posts made of high-strength pultruded glassfibre reinforced polyester (550 Mpa).

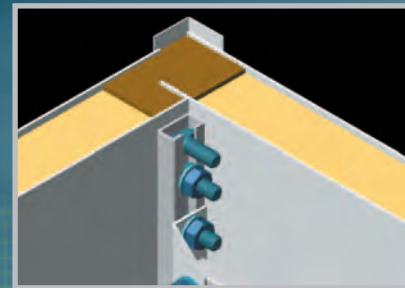
ARCTIC SHELTER

A very versatile system suited for even the most difficult specifications

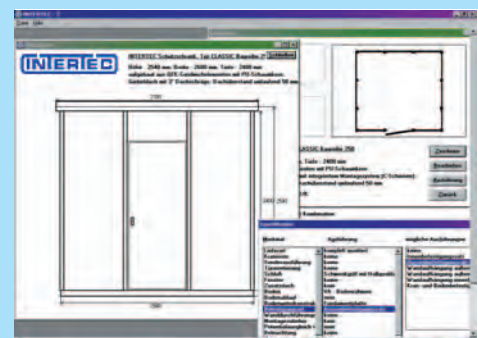

Electronic catalogue and design guide are available free of charge.

A I R C O N D I T I O N I N G

Air Conditioning

INTERTEC is more than a supplier of empty buildings. We have specialized in providing complete systems including engineering, documentation and intelligent cooling. Please consult us, we can offer an energy-saving solution to perfectly suit your air conditioning requirements.



Peltier Cooling System

A reliable solid-state cooling system for low cooling capacities.

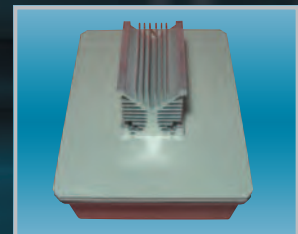

PELTIER Cooler

LCS Liquid Cooled Shelter

A patented system that transports heat directly from the point of origin to the outside, thus eliminating the use of energy-wasting air conditioning units.

Passive Cooling

Selected and designed with the assistance of the dynamic INTERSIM simulation software programme:

The cold of the desert night ensures climatic conditions during the day in accordance with customer's specifications.



Passive Cooler : Principle

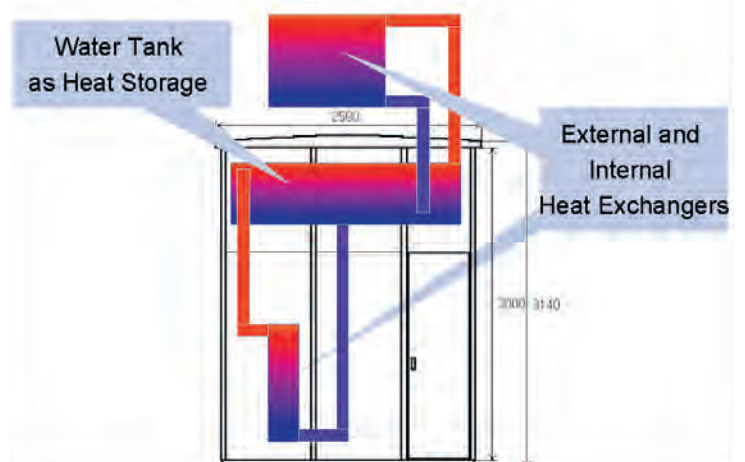

H E A T E R S

INTERTEC offers the widest selection of explosion-proof heaters worldwide.

- ATEX/CENELEC approvals for Europe
- CSA/NRTL approvals for America
- GOST approvals for the Russian Federation
- Many other national certificates, e.g. for Japan, the Czech Republic etc.

EXPLOSION-PROOF CONVECTION HEATERS

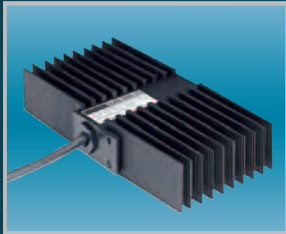

MINITHERM D

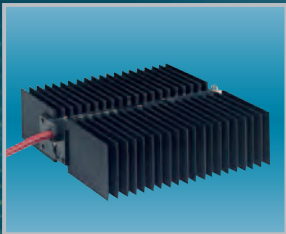

VARITHERM

- For freeze protection
- Installation in a horizontal or vertical position
- Choice of many different wattages
- Self-limiting or with thermostat in the connection cable allowing for quick and easy installation
- Fully sealed with silicone, protection degree to IP 68, reliable even in the harshest conditions
- Low thermal stress for long life
- Optional failure alarm



MICROTHERM

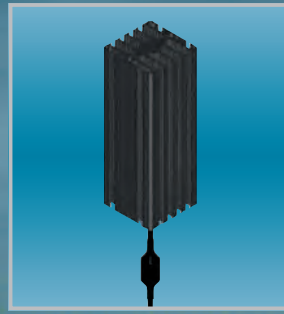

MULTITHERM

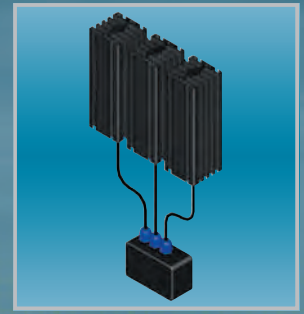

MULTITHERM

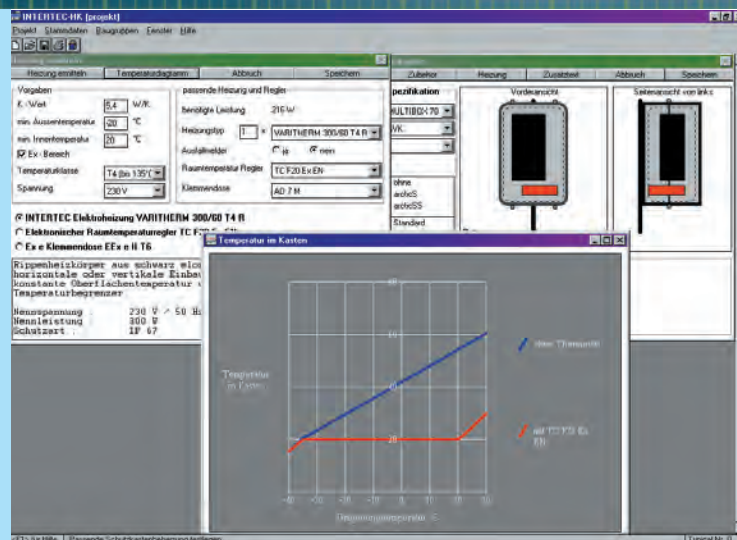

Lay-out and selection software free of charge



Heating blocks provide safe and energy-efficient heating and can be used wherever a small flat surface is available.



MINITHERM B

EXPLOSION-PROOF CONDUCTION HEATERS

E 155, a non-explosion-proof cabinet heater to IP 20

The Ex-heaters are also available in a more cost effective non-explosion-proof version.



E 155

NON-EXPLOSION-PROOF HEATERS

Explosion-Proof Heaters for Maintaining High Holding Temperatures

A very important issue is the very narrow range between the operating temperature and the maximum permitted temperature as defined by the temperature class that must not be exceeded in any case. INTERTEC Series HI heaters provide a sophisticated solution to this problem by using a patented electronic control system.

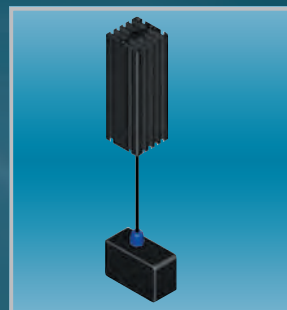

MULTITHERM HI



VARITHERM HI



The perfect solution: INTERTEC supplies the complete system consisting of enclosure and heater.



**STEAM AND
GLYCOL HEATERS**

INTERTEC offers heaters, reliable controllers and steam traps as well as the necessary expertise and know-how.

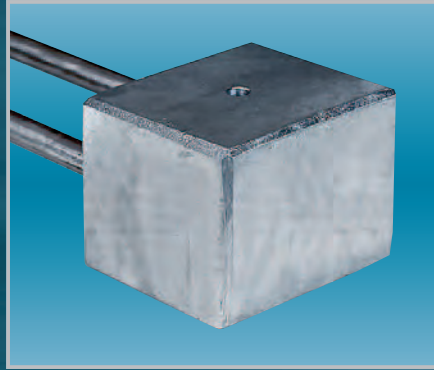

MINISTEAM



STEAMCONTROL

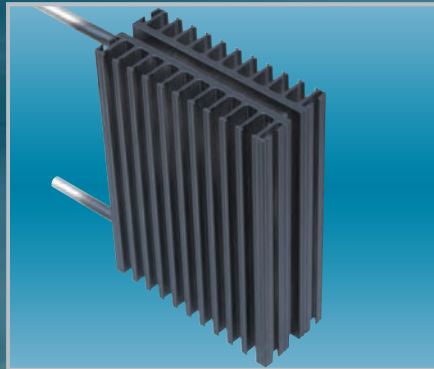

ALUSTEAM



DHU

From mineral-insulated (MI) stainless steel heating cables to self-limiting heater cables, INTERTEC offers the suitable cable, circuit engineering and know-how.

**EXPLOSION-PROOF
HEAT TRACING**

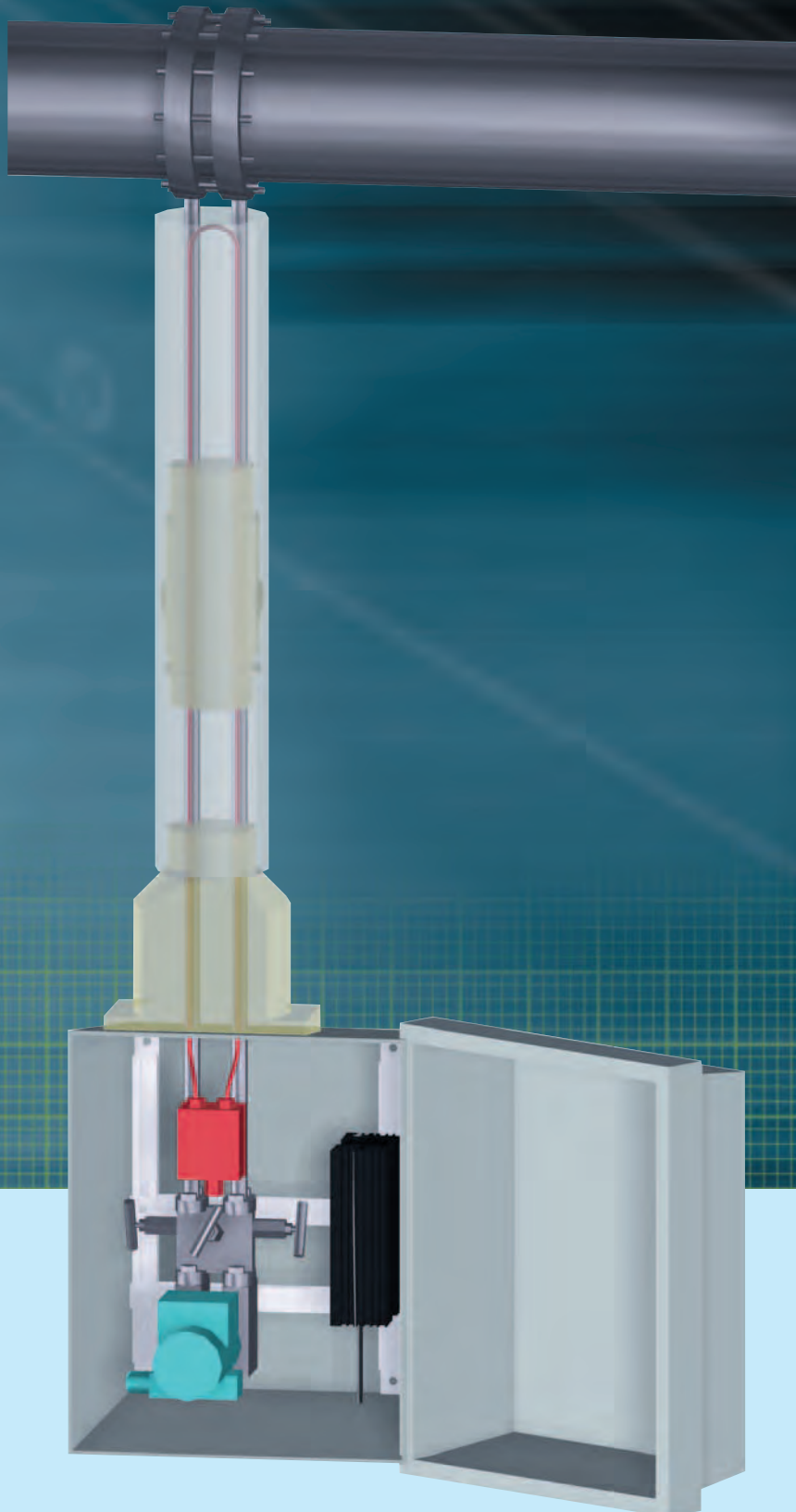

Self-limiting heater cable

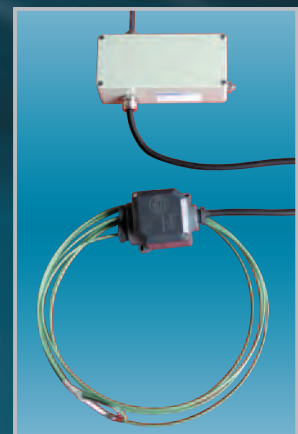

EASYTRACE, the self-limiting electronic controller for mineral-insulated cables

Why Protect?

For low long-term cost of ownership it is necessary to extend the life of instrumentation and to minimise plant down-time. Instrument enclosures are designed to help eliminate high maintenance costs. The failure through freezing of a single critical instrument can shut down an entire plant or process.



Freezing

Even with only trace amounts of water present, the measuring or impulse lines may progressively freeze. A freeze-protection heater can function effectively only with suitable insulation present. An instrument enclosure is a form of insulation which can be opened for maintenance and closed securely as often as required.

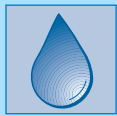

Condensation

Electronic instruments are likely to fail if moisture collects on the circuit boards. The dew point is likely to be reached in housings which are exposed to temperature changes in the open air. A heated and insulated enclosure will prevent condensation.

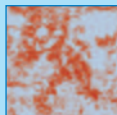

Corrosion

In the corrosive atmospheres of chemical plants, drops of condensation seldom consist of only pure water. Traces of acid (for example) have a corrosive effect even on stainless steel.



Solar (UV) Radiation

Maximum permissible operating temperatures of electronic equipment are often exceeded and not just in equatorial areas. A sunshade is the perfect solution, even in colder climates where direct sunlight is a factor.

INTERTEC HESS GmbH

Raffineriestraße 8
D-93333 Neustadt/Donau

Tel. (+49) 94 45/95 32-0
Fax (+49) 94 45/95 32 32

e-mail: info@intertec.info
www.intertec.info

Why Heat?

Heaters in instrument enclosures and protective cabinets are designed to provide freeze protection, prevent condensation and maintain constant temperatures.



Freezing

Even with traces of water in the medium (as e.g. in the air) there is a danger of freezing. In order to guarantee a safe and trouble-free operation throughout the year, measuring or sample lines and instruments have to be heated.

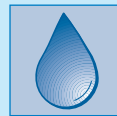

Condensation

Electronic instruments are likely to fail if moisture gets on the circuit board, and the dewpoint is likely to be reached in housings which are exposed to temperature changes in the open air. Heating the instrument, even with low power, reliably prevents condensation.

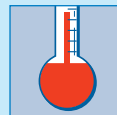

Temperature

In some media the temperature in lines and measuring instruments must not fall below a certain point; otherwise a fluid may solidify or condensing components of a gas might distort the measuring result.